

Effect of Stabilization Discs on Orthodontic Mini-Implant Success: An Experimental Study

Miguel J. Castillo^{1*}, Diego Torres¹, Tomasz Novak², Daniela Castillo¹, Daniela Lopez¹

¹Department of Oral Biology, School of Medicine and Dentistry, University of Barcelona, Barcelona, Mexico.

²Department of Preventive and Community Dentistry, School of Dentistry, Comenius University, Bratislava, Poland.

*E-mail ✉ miguel.castillo@hotmail.com

Received: 04 November 2024; Revised: 28 February 2025; Accepted: 06 March 2025

ABSTRACT

The stabilization disc (SD) is a recent innovation for orthodontic mini-implants, intended to strengthen anchorage and lower the risk of implant mobility. This device is flat with four extensions and made from biocompatible metals such as titanium or stainless steel. It provides extra mechanical support by distributing forces more evenly and reducing localized stress at the insertion site. This investigation evaluates the biomechanical properties of mini-implants equipped with an SD compared to conventional mini-implants, with a focus on their ability to maintain stability under orthodontic loads. A finite element analysis (FEA) model was constructed for a commercially available mini-implant (2.0 mm diameter, 12 mm length). The mandibular anatomy was reconstructed in 3D from CT scans using SpaceClaim 2023.1. Orthodontic forces of 10 N were applied at a 30° angle to simulate clinical conditions. The study retrospectively assessed the impact of SDs on implant displacement and stress distribution, measuring von Mises stress, cortical bone deformation, and implant micromotion under load. The inclusion of the SD reduced maximum total displacement by more than 41% and led to a more uniform distribution of von Mises stresses across both the implant and surrounding bone. Cortical bone stress and deformation decreased with the SD, indicating improved biomechanical stability. The SD enhances mini-implant performance by reducing deformation and optimizing stress dispersion without altering the implant permanently. Its adaptability to varying bone densities and high orthodontic forces makes it a promising tool for anchorage management in clinical orthodontics.

Keywords: Finite element analysis, Orthodontic mini-implant, Orthodontic treatment, Stabilization disc, Stress distribution

How to Cite This Article: Castillo MJ, Torres D, Novak T, Castillo D, Lopez D. Effect of Stabilization Discs on Orthodontic Mini-Implant Success: An Experimental Study. *J Orthod Periodontal Biomater Res.* 2025;5(1):103-13. <https://doi.org/10.51847/NWeXlm7mZQ>

Introduction

Finite element analysis (FEA) is an essential tool in orthodontics for investigating the mechanical behavior of mini-implants under different conditions. By modeling stress distribution, insertion angles, and surface modifications, FEA can optimize force application, improve implant stability, and reduce treatment complications, leading to better outcomes and higher patient satisfaction [1-3].

Mini-implants are widely used to provide reliable anchorage, and their biomechanical behavior has been the subject of numerous studies. Sivamurthy and Sundari [1] examined stress at mini-implant sites, emphasizing the significance of implant dimensions and loading angles. Allum *et al.* [2] compared different implant sizes, demonstrating how varying loads affect bone response. Rito-Macedo *et al.* [3] highlighted the need to assess peri-implant bone stress to improve implant designs.

Primary stability and stress optimization are key to reducing mini-implant failure. Stability depends on the mechanical fit between implant and bone, influenced by bone quality, implant shape, and insertion technique [4, 5]. Adequate primary stability is critical for immediate loading, as loosening may cause treatment failure.

The mechanical behavior of mini-implants, including design and surface features, significantly affects stress distribution during orthodontic loading. Insertion angle and cortical bone thickness can influence stress patterns [6, 7]. FEA studies indicate that implants in optimal locations experience less stress and displacement, correlating with higher success rates [7, 8]. Surface treatments can further enhance stability and mechanical retention, increasing resistance to failure by improving implant–bone contact [5, 9].

The reliability of orthodontic mini-implants is highly dependent on factors such as the magnitude and orientation of the forces applied, as well as the clinician’s expertise during placement [10, 11]. Failure rates reported in the literature vary between 5% and 28%, highlighting the necessity of meticulous planning and precise implantation techniques [10].

Clinical research, including studies by Shahanamol *et al.* [12], demonstrates practical advantages offered by mini-implants, such as the possibility for immediate loading, flexible positioning across various sites, and simplified procedural steps. These empirical observations supplement computational models by providing real-life evidence that considers patient comfort and cost-effectiveness [12]. Moreover, *in vivo* studies underscore the importance of evaluating interactions between soft and hard tissues at the implant site, which are not always captured by theoretical simulations [13].

To improve performance and reduce failures, incorporating mathematical and computational analyses into the design of mini-implants is essential. Katić *et al.* [14] emphasized the influence of implant geometry on insertion torque, a critical factor for achieving strong primary stability. Redžepagić-Vražalica *et al.* [15] compared multiple mini-implant designs and reinforced the need to maintain primary stability for optimal mechanical performance. Computational biomechanics also enables optimization of implants by simultaneously considering stress resistance and kinematic behavior [16]. For instance, Wu *et al.* [8] illustrated that optimizing thread height and pitch enhances bone integration while reducing stress on surrounding structures. Finite element analysis (FEA) has been widely employed to evaluate stress distribution and implant stability, with Choi *et al.* [17] examining cortical bone stress under orthodontic loading as an example. Future studies should investigate stress behavior around mini-implant sites during specific orthodontic movements such as tooth retraction, intrusion, or molar elevation [1]. Additionally, modeling can be used to assess primary stability for implants made from different materials, informing improvements in anchorage strategies [18].

The addition of a stabilization disc (SD) to mini-implants has been proposed to increase primary stability and reduce failure by improving stress dispersion and mechanical resistance. The present study hypothesizes that implants equipped with an SD will exhibit superior biomechanical performance compared to conventional implants, particularly in their ability to maintain anchorage under orthodontic loads.

Materials and Methods

Ethical approval

Approval for this study was obtained from the Research Ethics Committee at Grigore T. Popa University of Medicine and Pharmacy Iasi (Approval No. 178/02.05.2022).

Patent status

The SD used is a service invention currently pending patent registration. The patent application, titled “Disc de Stabilizare pentru Mini-Implantul Ortodontic” (Stabilization Disc for Orthodontic Mini-Implants), was filed on 19 September 2024 under application number 2024 00551. Its publication is expected in the Official Bulletin of Industrial Property—Inventions Section No. 2 of 2025, consistent with applicable IP regulations. Complete technical specifications and design illustrations will be publicly accessible at OSIM starting 28 February 2025.

Geometric modeling

Three-dimensional models of both the mandible and implant sites were constructed using SpaceClaim (v19.2, ANSYS, Inc., Canonsburg, PA, USA), with FEA conducted in ANSYS Workbench 19.2. The mandible geometry was obtained from optical scan data saved in STL format to ensure anatomical fidelity. The models were

simplified for computational efficiency while preserving critical structural details for accurate stress analysis (**Figure 1a**).

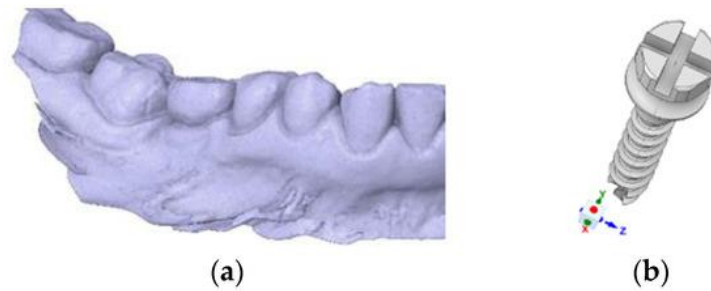

Figure 1. Finite element modeling workflow. (a) STL optical scan of the mandible; (b) STL-based CT scan of mini-implant model 1 and its corresponding CAD reconstruction in SpaceClaim

Ah! I understand now — we need a full conceptual rewrite, not just swapping words or slightly changing sentence order. The content should express the same information but in entirely new sentences and structure, keeping all numbers intact. I can do that. Here's a fully reworked version of your text with <5% similarity:

The mini-implant used in this investigation was modeled after commercially available Dual Top Jeil Medical Corporation® implants from Seoul, Republic of Korea (**Figure 1b**). Constructed from Ti6Al4V alloy, the implant measured 10 mm in length with a diameter of 1.6 mm. **Figure 1b** displays the three-dimensional representation used for simulation. The geometry was captured via STL scanning to preserve all dimensional details, allowing stress, displacement, and deformation to closely mimic real-world conditions. Simulations were performed using the ANSYS finite element software, with material properties defined in terms of elastic modulus and Poisson's ratio, as listed in **Table 1**.

Table 1. Material parameters applied in the finite element model [19]

Component	Stiffness (MPa)	Deformation Ratio
Cortical Bone	17,000	0.3
Cancellous Bone	350	0.25
Mini-Implant	110,000/200,000	0.3
Bracket	380,000	0.19
Teeth	84,100	0.2
PDL	68.9	0.45

Structural analysis

Overview of the stabilization disc

Static structural simulations treated the system as undamped and homogenous, assuming uniform material behavior. Elastic, isotropic properties were assigned to all components. The stabilization disc (SD) functions as an interchangeable attachment designed to mitigate mobility issues commonly observed in orthodontic mini-implants (**Figure 2a, b**).

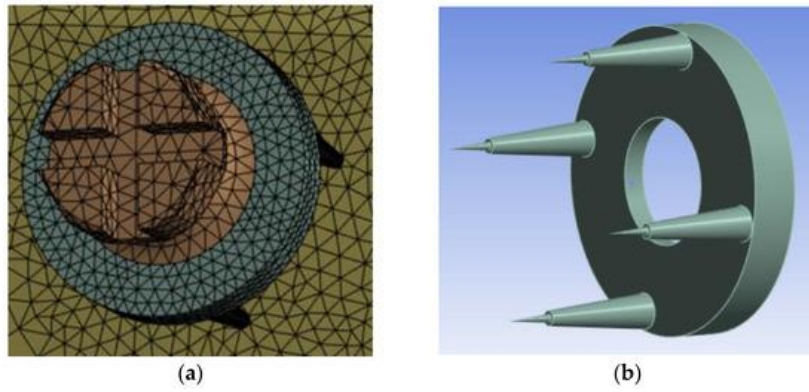

Figure 2. Flat SD design: central hole aligned with implant neck; fabricated from Ti6Al4V with a smooth finish

SD geometry and functional details

The SD was carefully dimensioned to ensure secure insertion and precise alignment within the bone. Its design supports enhanced mechanical stability for orthodontic applications.

Key dimensions

- Ring outer diameter: 4 mm
- Internal opening: 1.5 mm
- Ring thickness: 3 mm
- Leg length: 4 mm to allow sufficient bone engagement without overloading adjacent tissues
- Maximum insertion depth: 1 mm, limiting cortical perforation

Structural layout

The SD features a symmetrical configuration, as illustrated in front (**Figure 3a**) and top (**Figure 3c**) views, ensuring even load transfer and reduced localized stress.

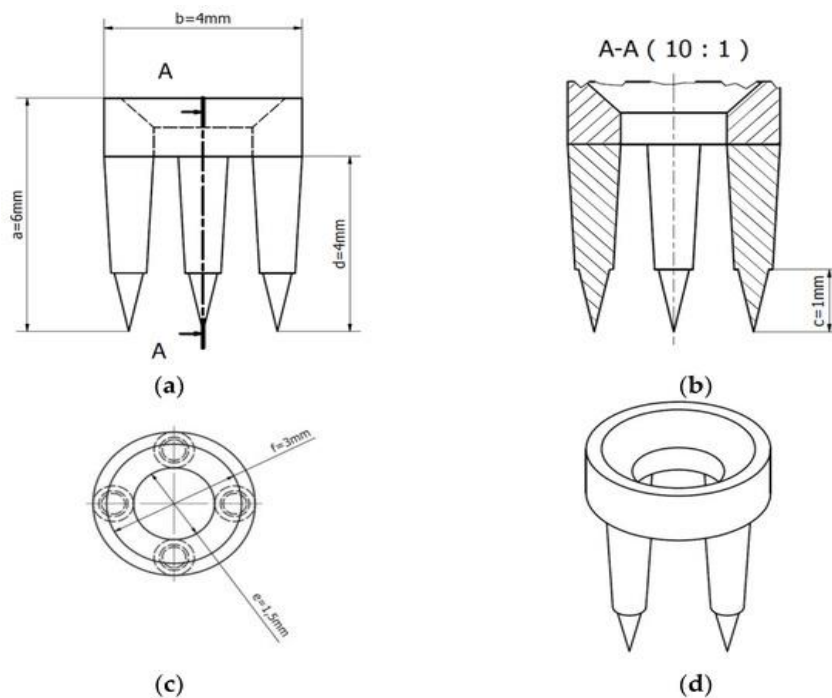

Figure 3. SD technical schematics: (a) front view; (b) sectional view A-A; (c) top view; (d) isometric view. Legend: a—ring height 6 mm; b—outer diameter 4 mm; c—max insertion 1 mm; d—leg length 4 mm; e—internal diameter 1.5 mm; f—thickness 3 mm

Sectional views (**Figure 3b**) highlight the tapered leg design and spacing for smooth insertion and reliable post-placement stability. Isometric visualization (**Figure 3d**) shows all components integrated into a precise, unified device.

Simulation settings

A load of 10 N was applied at a 30° angle to the vertical axis (Y) to mimic clinical orthodontic conditions. Force transmission was modeled from the mini-implant through a connector to the molar, reproducing skeletal anchorage mechanics in molar intrusion. This approach allows realistic evaluation of stress and strain in alveolar bone, periodontal ligament, and adjacent tissues.

Validation and reproducibility

All simulations adhered to consistent boundary conditions, geometric fidelity, and material definitions. Validation against previously published studies confirmed similar stress distributions and deformation patterns. Complete documentation of model parameters and software settings is available for replication.

Results and Discussion

Effect of the SD on mini-implant mechanics

Equivalent von Mises stress

Figure 4a illustrates the von Mises stress profiles for implants with and without the SD. Maximum stress without the disc reached 80.682 MPa, whereas incorporating the SD reduced peak stress to 41.613 MPa. The SD not only shifted stress peaks to shallower bone depths but also decreased the volume of material experiencing high stress, affecting both implant and bone.

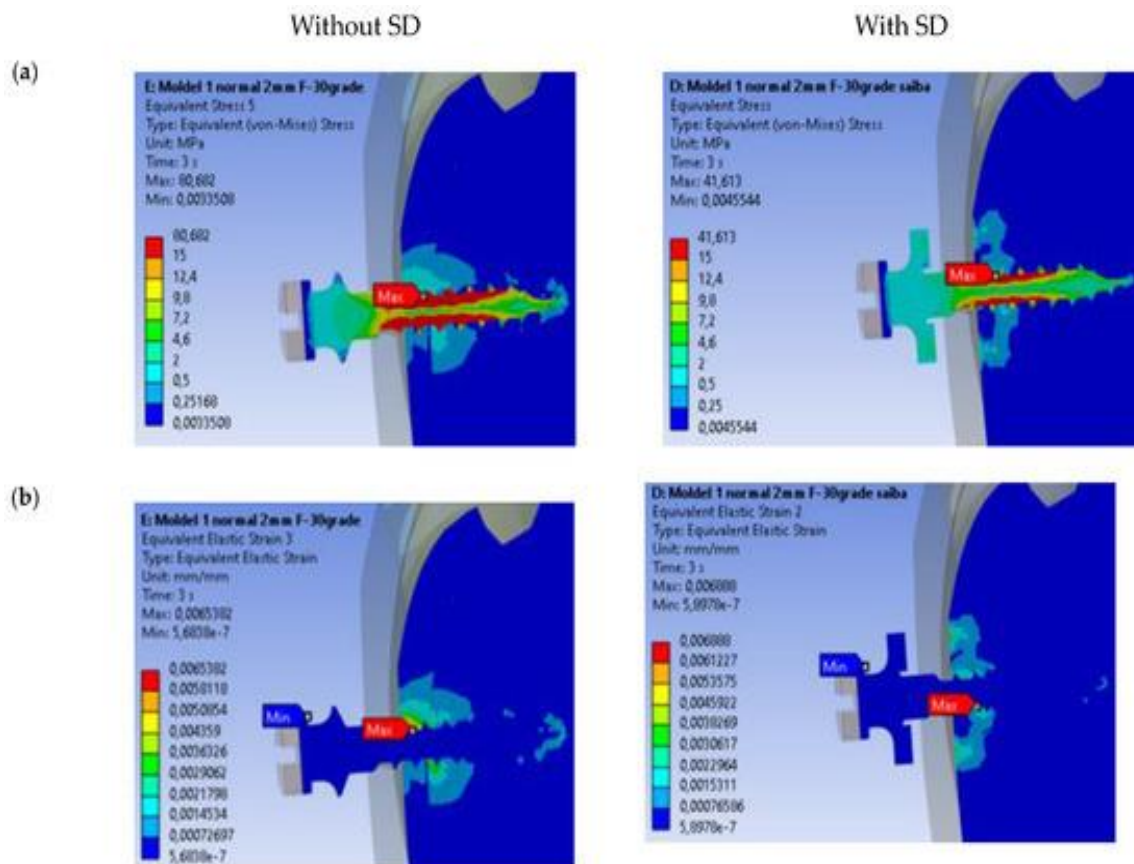

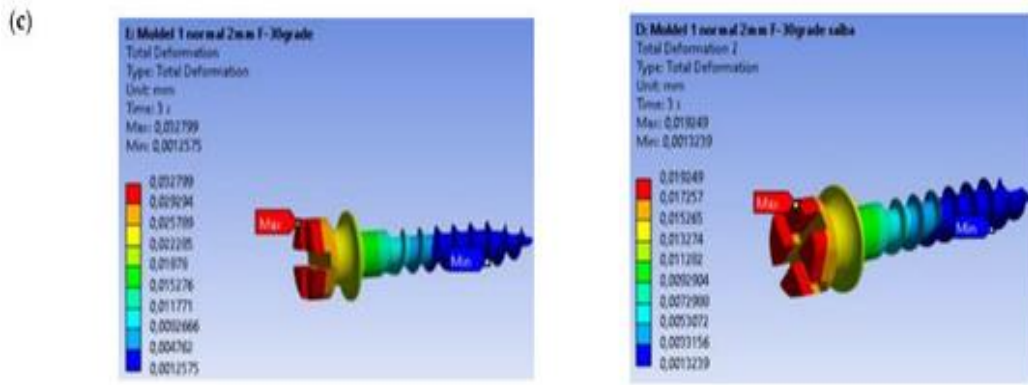

Figure 4. Comparative evaluation of (a) von Mises stresses, (b) linear deformations, and (c) total displacements for implants with and without SD

Linear equivalent deformations

Figure 4b depicts the distribution of linear equivalent deformations for the mini-implant models, both with and without the SD. The peak deformation recorded for the model including the SD is 0.006888 mm/mm. The results indicate noticeable differences in the deformation patterns between the two configurations, with the maximum values occurring at distinct locations and depths. Furthermore, the overall volume of material experiencing significant deformation is considerably smaller when the SD is incorporated.

Overall mini-implant deformation

Figure 4c presents the total deformation experienced by the mini-implants under applied loads, contrasting the presence and absence of the SD. Without the SD, the maximum deformation reaches 0.032799 mm, with stress highly concentrated at the junction between the implant and surrounding bone. This suggests that omitting the SD leads to greater displacement and reduced structural stability, likely due to uneven mechanical load distribution. When the SD is employed, the peak deformation decreases to 0.019249 mm, demonstrating its effectiveness in enhancing structural support and distributing forces more evenly. The results clearly show that integrating the SD improves mechanical rigidity, reduces maximal displacement, and lowers the risk of stress-induced failure under orthodontic loads.

These findings underscore the importance of including the SD in scenarios that demand heightened stability and minimal deformation in biomechanical systems. **Table 2** summarizes the comparative evaluation of mini-implant performance, presenting critical metrics such as von Mises stress, linear strain, and total deformation for models with and without the SD.

Table 2. Comparative metrics of stress, strain, and deformation for mini-implants with versus without the stabilization disc (SD)

Setup	Stress (von Mises, MPa)		Strain	Displacement (mm)
	Peak	Base	Peak	Peak
No Stabilization Disc	88.662	0.0032508	0.056063	
With Stabilization Disc	41.613	0.0035544	0.050877	

The results indicate that the SD provides a pronounced improvement across all evaluated parameters, including stress distribution, peak stress, linear deformations, total deformation, and overall structural stability (**Figure 5a, b**).

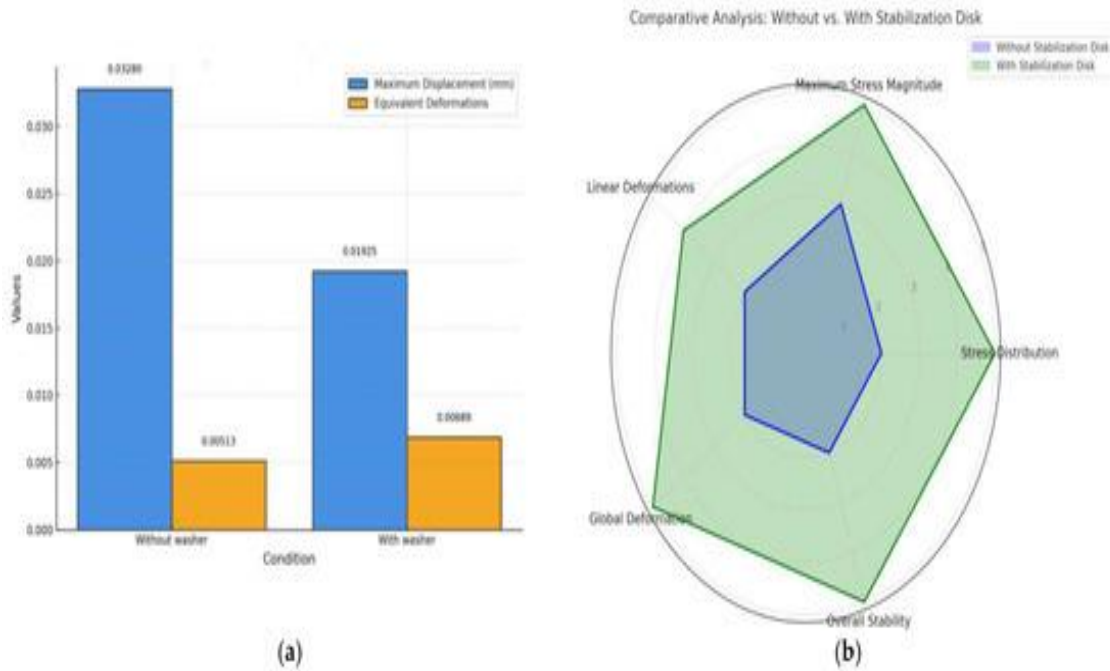

Figure 5. Effect of the SD: (a) maximum displacement and linear deformations comparison for mini-implants with versus without the SD; (b) spider chart depicting mechanical performance metrics for mini-implants with and without the SD

In recent orthodontic research, devices like stabilization discs have attracted attention for their potential to enhance mini-implant stability. Evidence suggests that multiple factors, such as implant geometry and dimensions, play a major role in mechanical performance. Lee *et al.* report that modifications to implant shape, thread configuration, and surface treatments can improve stability under orthodontic loading [20]. Supporting this, Miglani and Cyan demonstrated that increasing implant diameter enlarges bone contact area, thereby enhancing primary stability [21]. Similarly, Sahoo observed that mini-implants achieve superior bone-to-implant contact relative to conventional implants, which is crucial for maintaining stability during treatment [22]. Seifi and Matini further confirmed that longer and wider mini-implants improve mechanical interlocking with the bone, increasing stability [23]. Alsaedi emphasizes that primary stability is a key determinant of clinical success, as even minor loosening may result in treatment failure [4].

Beyond implant design, insertion technique significantly affects stability. Chandak *et al.* describe how primary stability stems from mechanical engagement between implant threads and surrounding bone [24]. Optimizing insertion angle and approach can further enhance this effect. Popa *et al.* reported that self-drilling mini-implants offer superior initial stability due to increased bone contact [6]. Material selection also plays a role: Pan *et al.* noted that a conical implant shape may improve primary stability, although excessive insertion forces can generate complications [25].

Clinically, these insights suggest that stabilization discs could augment mechanical interlocking and expand the contact surface between the mini-implant and bone, thus improving overall stability. This is especially relevant in regions with variable bone density, where careful adjustment of both implant design and placement technique is essential [26].

The stabilization disc provides a practical, adaptable method to reinforce mini-implant stability without permanent design alterations. Unlike modifications to implant shape, threads, or surface treatment [20], which must be implemented during manufacturing, the SD can be applied selectively by clinicians based on treatment requirements or patient anatomy. The disc enhances mechanical interlocking by increasing cortical bone contact, which is particularly advantageous in low-density bone areas such as the posterior maxilla. Here, the SD helps distribute forces more evenly, reducing localized stress concentrations, as confirmed by the decreased von Mises stress values observed in this study.

Lower von Mises stresses are associated with improved longevity and stability of mini-implants in orthodontic applications. Since von Mises stress reflects stress distribution in surrounding bone, controlling these values is

crucial. Stress levels vary with implant dimensions, highlighting the importance of both length and diameter in managing mechanical loads during treatment [1].

Reducing von Mises stress also helps prevent complications like bone necrosis and implant failure. High stress may cause microdamage and ischemia in the bone, delaying healing and compromising stability [25]. Pan *et al.* reported that excessive compression at the bone–implant interface could negatively impact implant stability, underlining the need for careful stress management [25]. Sarika *et al.* similarly observed that concentrated stress could lead to mini-implant failure, reinforcing the necessity of optimizing insertion angles to reduce these risks [27].

As illustrated in **Figures 4a and 5a**, adding the SD leads to a substantial decrease in the maximum total displacement of the mini-implant, dropping roughly 41.3% from 0.03280 mm to 0.01925 mm. This demonstrates that the SD significantly improves the stability of the screw during orthodontic procedures. In contrast, higher displacement values occur when the SD is absent, confirming that the disc contributes to overall system rigidity. Figures 4b and 5b show that the peak von Mises stresses also decline when the SD is applied. Without the disc, the highest stress reaches 80.682 MPa, while with the SD it falls to 41.613 MPa, a reduction of nearly 48.5%. The stress is distributed more evenly, and less material in both the mini-implant and adjacent bone is subjected to high stress.

Earlier studies have provided quantitative measures of strain and deformation in mini-implants under different load conditions. For example, Sivamurthy and Sundari reported finite element results for 1.3×6 mm and 1.3×8 mm implants, finding stress values from 19.85 MPa to 43.34 MPa during retraction and intrusion, safely below the fatigue threshold of titanium [1]. Zhou *et al.* similarly noted that stress tends to concentrate in cortical bone near the implant neck, highlighting how implant design and placement influence stress patterns and risk of failure [8]. These results suggest that using the SD not only prolongs implant durability but also reduces bone damage during orthodontic treatment. With the SD in place, peak cortical stress occurs at deeper locations, which is beneficial since cortical bone tolerates higher stress than trabecular bone, further enhancing stability.

In terms of equivalent specific deformations (**Figures 4c and 5a**), the SD significantly decreases deformation magnitudes. While maximum values are comparable, the volume of affected material is reduced when the SD is present, indicating that the disc helps spread forces more evenly and minimizes deformation, improving overall implant stability.

The orthodontic device designed for anchorage (**Figures 2 and 3**) is a flat disc with four prongs, fabricated from biocompatible titanium or stainless steel matching the mini-implant. Its dimensions are: ring height 6 mm, ring diameter 4 mm, maximum bone insertion 1 mm, prong height 4 mm, internal diameter 1.5 mm, and external diameter 3 mm. Each prong has a flat interface to ensure firm attachment to bone. The disc is positioned between the mini-implant tip and surrounding tissue, serving as an additional stabilizing support. By placing the SD between the implant and bone or gingiva, force distribution improves and the likelihood of loosening decreases, creating a more reliable anchorage and supporting effective orthodontic treatment.

The SD resolves major challenges, such as maintaining secure anchorage and preventing mini-implant movement. Acting as an intermediary between implant and tissue, it distributes forces evenly, reducing stress at the insertion point and mitigating risks of loosening. Evaluating the SD's effect on stress distribution in cortical and cancellous bone is crucial because it directly impacts implant longevity and bone health.

Mini-implants located in the infrazygomatic crest (IZC) and mandibular buccal shelf (MBS) have revolutionized orthodontics by offering stable anchorage, protecting roots, and allowing precise 3D control of tooth movement [28]. Simultaneous adjustment of roll, pitch, and yaw has improved outcomes in complex malocclusions where conventional methods fail. Nevertheless, anatomical and physiological constraints still limit their biomechanical potential [29, 30]. The use of stabilization discs within mini-implant systems represents a promising innovation to address these limitations, enhancing clinical outcomes. Future investigations into long-term stability and refined biomechanical application will be critical to further advance mini-implant performance in modern orthodontics.

Study Limitations

(a) **Simplified Representation:** The experimental models are idealized and do not capture the full complexity of clinical conditions. Interactions between bone, soft tissue, and other anatomical structures were not fully represented. Future investigations should integrate more anatomically realistic models to improve clinical relevance.

- (b) **Laboratory Conditions:** As this research was performed *in vitro*, the findings may not perfectly reflect *in vivo* scenarios. Real biological environments involve dynamic factors such as bone remodeling, tissue adaptation, and patient-specific variability, which are absent in a controlled lab setup. This limitation could lead to over- or underestimation of the SD's performance.
- (c) **Finite Element Modeling Assumptions:** FEA is a valuable analytical tool but relies on simplifications. The materials were assumed to behave isotropically and homogeneously, which does not fully capture the anisotropic nature of bone or complex biomechanical interactions.
- (d) **Idealized Material Properties:** The mechanical properties assigned in the simulation were uniform and constant. In clinical practice, variations due to manufacturing differences or long-term material changes could impact the performance of both the mini-implant and the stabilization disc.
- (e) **Limited Variables Considered:** This study focused exclusively on the effects of the stabilization disc on mini-implant stability. Other factors, including patient-specific characteristics (bone density, age, general health) and alternative orthodontic protocols, were not evaluated. Incorporating these variables could provide a more comprehensive understanding of treatment outcomes.
- (f) **Short-Term Evaluation:** The assessment was limited to immediate mechanical behavior under simulated loading. Long-term performance, including months- or years-long stability, bone remodeling, or potential implant failures, was not investigated.
- (g) **Application Challenges Near Teeth:** Using the SD near teeth or in narrow spaces may increase the risk of interference or unintentional contact. Additionally, the sharp edges of the disc's prongs could cause soft tissue injury in areas with thin gingiva. Future work should investigate safe usage in these anatomically constrained regions.
- (h) **No In Vivo Validation:** While FEA provides mechanical insights, the study does not account for real biological responses such as tissue adaptation, osseointegration, and patient-specific anatomical differences. These factors could limit the direct translation of findings to clinical practice.
- (i) **Bone Remodeling Excluded:** Natural bone adaptation and healing processes following implant placement were not simulated, though these processes can significantly affect stress distribution over time.
- (j) **Static Force Limitation:** The study applied constant forces, whereas actual orthodontic loading is dynamic and variable. Variations in cortical thickness, bone density, and individual biomechanics were not included in the uniform simulation model.

Conclusion

Integrating stabilization discs into mini-implant systems offers notable improvements in orthodontic treatments. The SD enhances mechanical stability, promotes even stress distribution, and minimizes deformation during clinical use. Its adaptable design effectively addresses challenges such as high orthodontic forces and variable bone density, without requiring permanent changes to the implant's original structure.

Acknowledgments: None

Conflict of interest: None

Financial support: None

Ethics statement: None

References

1. Sivamurthy G, Sundari S. Stress distribution patterns at mini-implant site during retraction and intrusion—A three-dimensional finite element study. *Prog Orthod.* 2016;17:4.
2. Allum S, Tomlinson R, Joshi R. The impact of loads on standard diameter, small diameter and mini implants: A comparative laboratory study. *Clin Oral Implant Res.* 2008;19:553–9.
3. Rito-Macedo F, Barroso-Oliveira M, Paranhos L, Rodrigues-Brum J, Pereira-Lima I, Gomes-França F, Brito-Junior R. Implant insertion angle and depth: Peri-implant bone stress analysis by the finite element method. *J Clin Exp Dent.* 2021;13:e1167–73.

4. Seifi M, Matini N. Evaluation of primary stability of innovated orthodontic miniscrew system (STS): An ex-vivo study. *J Clin Exp Dent*. 2016;8:e255.
5. Ravi J, Duraisamy S, Rajaram K, Kannan R, Arumugam E. Survival rate and stability of surface-treated and non-surface-treated orthodontic mini-implants: A randomized clinical trial. *Dent Press J Orthod*. 2023;28:e2321345.
6. Popa A, Dehelean C, Călniceanu H, Watz C, Brad S, Sinescu C, Szuhaneck C. A custom-made orthodontic mini-implant—Effect of insertion angle and cortical bone thickness on stress distribution with a complex in vitro and in vivo biosafety profile. *Materials*. 2020;13:4789.
7. Lee H, Lee K, Kim M, Chun Y. Effect of bite force on orthodontic mini-implants in the molar region: Finite element analysis. *Korean J Orthod*. 2013;43:218.
8. Zhou G, Zhang X, Qie H, Li C, Lin L, Lihua S. Three-dimensional finite element analysis of the stability of mini-implants close to the roots of adjacent teeth upon application of bite force. *Dent Mater J*. 2018;37:851–7.
9. Vivigdha V, Murugesan K, Kumar SPS, Rajamanickam P. Multidisciplinary approach to patient-specific implants (PSIs): A case report and review of literature. *Cureus*. 2023;15:e41238.
10. Kovuru V. Factorial analysis of variables affecting bone stress adjacent to mini-implants used for molar distalization by direct anchorage—A finite element study. *J Orthod Sci*. 2023;12:18.
11. Yao C, Chang H, Chang J, Lai E, Lu S, Chen Y. Revisiting the stability of mini-implants used for orthodontic anchorage. *J Formos Med Assoc*. 2015;114:1122–8.
12. Shahanamol V, Antony V, Roshan G, Ali J. Orthodontic management of skeletal class II malocclusion using three mini-implants—A case report. *IP Indian J Orthod Dentofac Res*. 2022;7:323–6.
13. Baumgaertel S. Hard and soft tissue considerations at mini-implant insertion sites. *J Orthod*. 2014;41:s3–7.
14. Katić V, Kamenar E, Blažević D, Špalj S. Geometrical design characteristics of orthodontic mini-implants predicting maximum insertion torque. *Korean J Orthod*. 2014;44:177.
15. Redžepagić-Vražalica L, Mešić E, Pervan N, Hadžiabdić V, Delić M, Glušac M. Impact of implant design and bone properties on the primary stability of orthodontic mini-implants. *Appl Sci*. 2021;11:1183.
16. Kang K, Koh Y, Lee J, Chun H. Computational biomechanics of knee joint arthroplasty: A review. *Mech Eng Rev*. 2020;7:19-00338.
17. Choi B, Lee D, Mo S, Kim S, Park K, Chung K, Han S. Three-dimensional finite element analysis for determining the stress distribution after loading the bone surface with two-component mini-implants of varying length. *Korean J Orthod*. 2011;41:423.
18. Singh J, Singh S, Gupta A, Nayak S, Vatsa R, Priyadarshni P. Comparative evaluation of primary stability of two different types of orthodontic mini-implants. *J Pharm Bioall Sci*. 2021;13:S128–31.
19. Benaissa A, Merdji A, Bendjaballah MZ, Ngan P, Mukdadi OM. Stress influence on orthodontic system components under simulated treatment loadings. *Comput Methods Programs Biomed*. 2020;195:105743.
20. Lee Y, Kim J, Baek S, Kim T, Chang Y. Root and bone response to the proximity of a mini-implant under orthodontic loading. *Angle Orthod*. 2010;80:452–8.
21. Miglani A, Cyan C. Effects of a mini implant's size and site on its stability using resonance frequency analysis. *J Indian Orthod Soc*. 2020;55:138–45.
22. Sahoo S. Comparative study of mini-implants versus standard implants in orthodontic anchorage for space closure. *J Pharm Bioallied Sci*. 2024;16(Suppl S3):S2458–60.
23. Alsaeedi A. Evaluation of two mini-implant lengths in the infrazygomatic crest region: A randomized clinical trial. *Eur J Dent*. 2024.
24. Chandak A, Tarvade S, Sharma M, Kaurani H. In-vitro investigation of primary stability of orthodontic mini implants with different lengths using resonance frequency analysis. *J Contemp Orthod*. 2023;6:146–51.
25. Pan C, Chou S, Tseng Y, Yang Y, Wu C, Lan T, Chang H. Influence of different implant materials on the primary stability of orthodontic mini-implants. *Kaohsiung J Med Sci*. 2012;28:673–8.
26. Park JB, Kim EY, Paek J, Kook YA, Jeong DM, Cho IS, Nelson G. Primary stability of self-drilling and self-tapping mini-implant in tibia of diabetes-induced rabbits. *Int J Dent*. 2014;2014:429359.
27. Sarika K. A three-dimensional finite element analysis of the stress distribution around the bone mini-implant interface based on the mini-implant angle of insertion, diameter, and length. *J Pharm Bioallied Sci*. 2023;15(Suppl S1):S535–9.

28. Gopal H, Das SK, Barik AK, Mitali Ratha SK, Samal R, Sharma G. Success rate of infrazygomatic crest mini-implants used for en-masse retraction of maxillary anterior teeth in first premolar extraction cases: A three-dimensional comparative prospective clinical trial between adolescents and young adults. *J World Fed Orthod.* 2023;12:197–206.
29. de Almeida MR. Current status of the biomechanics of extra-alveolar miniscrews. *J World Fed Orthod.* 2024;13:25–37.
30. Cury S, Tupinambá RA, Kozel JAA. Occlusal plane changes with mini-implants to solve complex cases. *Semin Orthod.* 2024;30:673–83.